



SPO16/20 Two Post Lifts

HEAVY-DUTY SYMMETRIC LIFTS

16,000 lbs. / 20,000 lbs. CAPACITIES



Available with
SHOCKWAVE™

SPOTRIO™ HDSERIES LIFTS

16,000 lbs. / 20,000 lbs. capacities



Model shown: SPO20U0T0RD
20,000 lbs. capacity SHOCKWAVE-equipped lift

This lift is designed for most class 4 and 5 vehicles.
Some vehicles within each class may exceed arm capacity but not the lift capacity.
Please consult vehicle axle information and lift manual for more information.



The World's Most Trusted Lift.™

www.rotarylif.com



SPO16/20 Two Post Lifts

16,000 lbs. and 20,000 lbs. CAPACITIES

NEW SUPER DUTY SYMMETRIC LIFTS WITH GREATER LIFTING CAPACITIES AND PATENTED THREE-STAGE TRIO™ ARMS!

INDUSTRY LEADING VERSATILITY:

PICK UP A GREATER VARIETY OF VEHICLES FASTER AND EASIER ALL ON ONE HEAVY DUTY 2-POST LIFT.

Packed with industry leading features, these new SPO Series lifts combine high capacity, a low profile stance, wider options and extreme arm reach possibilities with patented lifting speed!

SHOP VERSATILITY

*From Class 1 to Class 5 vehicles, low profile TRIO™ arms maximize lifting capabilities as never before.**

Service your entire fleet on a single lift!

With capacities up to 20,000 pounds and optional low ceiling models, you can be assured we have a lift for all your service jobs.

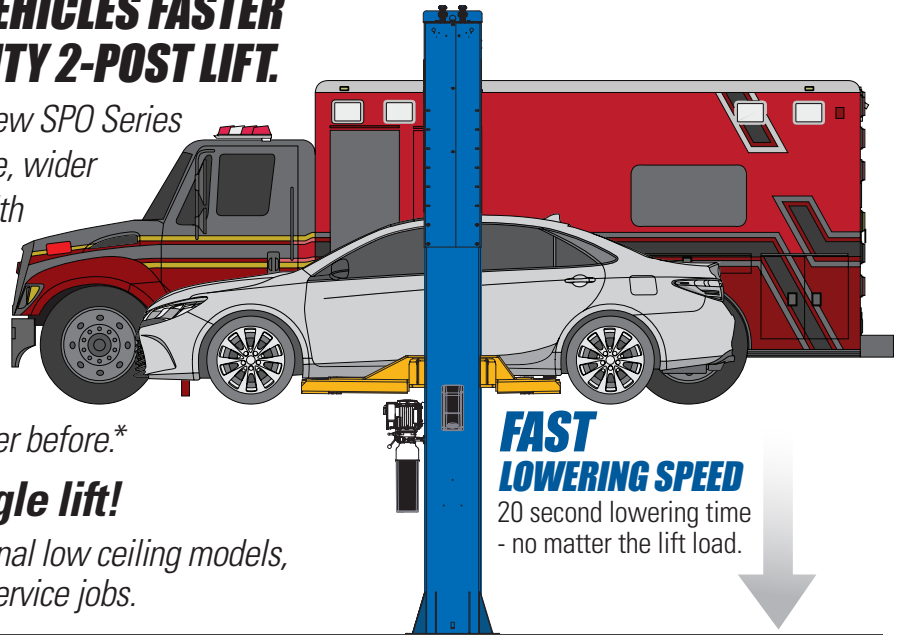

FAST LOWERING SPEED

20 second lowering time - no matter the lift load.

SPO TRIO™ ARMS:

THREE STAGES OF FLEXIBILITY IN A TWO-PIECE ARM!

No extra heavy inner arms to move for positioning. Greater productivity equals higher profits per bay, every day!

TRIO 3-STAGE ARM RANGE

STAGE ONE

TRIO arm at full retraction
34 11/16" MINIMUM ARM REACH

STAGE TWO

Single inner arms shown at full arm extension

64" MAXIMUM ARM REACH

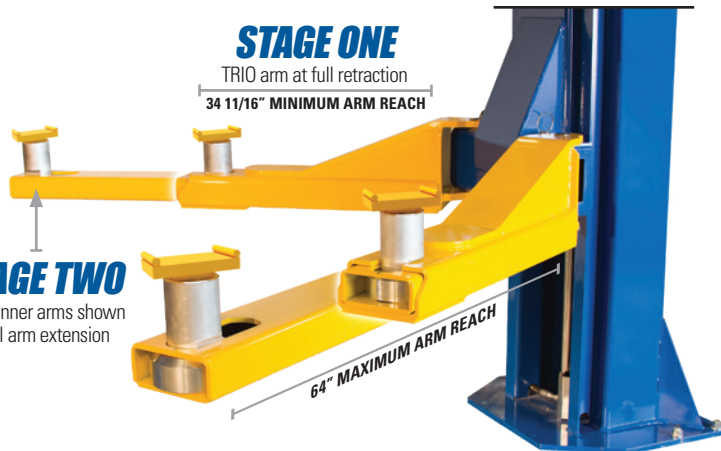

STAGE THREE ADAPTER REACH

Patented multi-position adapter slider

Integrated "third stage" adapter adjustment easily slides to a pinpoint vehicle contact location without having to move heavy inner arms - saving technicians even greater set-up time!

PATENTED STAGE THREE RANGE

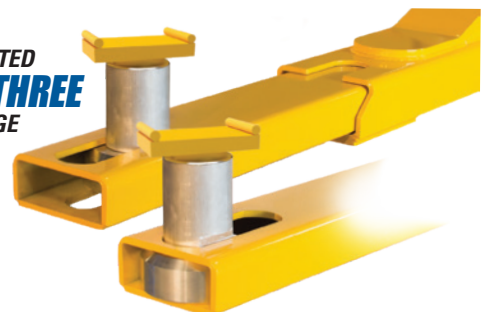

*NOTE: Level bay floors provide the best underbody clearance needed to accommodate the broadest range of vehicles to spot and lift. Wide setting installations create the best tire clearance on shorter wheelbases. Vehicle axle weight MUST NOT EXCEED one half of total lift capability. Maximum arm load is 1/4 of lift rated capacity.

LIFT FEATURES

HIGHER LIFTING CAPACITIES

SPO16: 16,000 lbs. (7257kg)

SPO20: 20,000 lbs. (9072kg)

MAXIMIZE RISE HEIGHT

Rise is measured from floor to adapter in the lowest and highest position.

77 - 31/32" to 80 - 1/32"
(1979 to 2035mm)

THE ORIGINAL "DOUBLE S" COLUMN DESIGN

The single piece column design maximizes column strength.



SHOCKWAVE™ EQUIPPED

Supercharge your lift with SHOCKWAVE™ and make your lifting speed twice as fast!

36 SECOND RISE TIME!*

Patented DC power system reduces operating costs.**

Accelerate productivity immediately!

Increase service orders per bay!

Added productivity equals EXTRA PROFIT!

*Actual rise times may vary depending on weight of the vehicle.

**Shockwave's patent pending DC power system uses two standard Group 24 batteries with built in 110v power battery charger. Batteries not included.

SPOTLINE™ Motion Activated Laser

Standard with SHOCKWAVE-equipped lifts, this laser-guided system helps center vehicles quickly and accurately the first time.

EFFICIENT LOCKING SYSTEM

Column locks engage every 4" and are fully accessible for maintenance.

AIR OPERATED LOCK RELEASE

Single point air operated lock release.

AUTOMATIC ARM RESTRAINTS

Restraints engage when the lift is raised.

MULTIPLE HEIGHT ADJUSTMENT OPTIONS

Standard height options
from 15' to 16' 6"
(4572 - 5029mm)

Low ceiling adjustments
from 13' 6" to 14' 6"
(4115 - 4420mm)

SYMETRICAL DESIGN WITH THREE COLUMN WIDTH OPTIONS

Improve vehicle access for your shop.
From 12' 11" (3937mm) to 13' 11" (4242mm)

PATENTED TRIO™ ARMS: THREE STAGES OF FLEXIBILITY IN A TWO-PIECE ARM

Spotting vehicles has never been faster and easier.

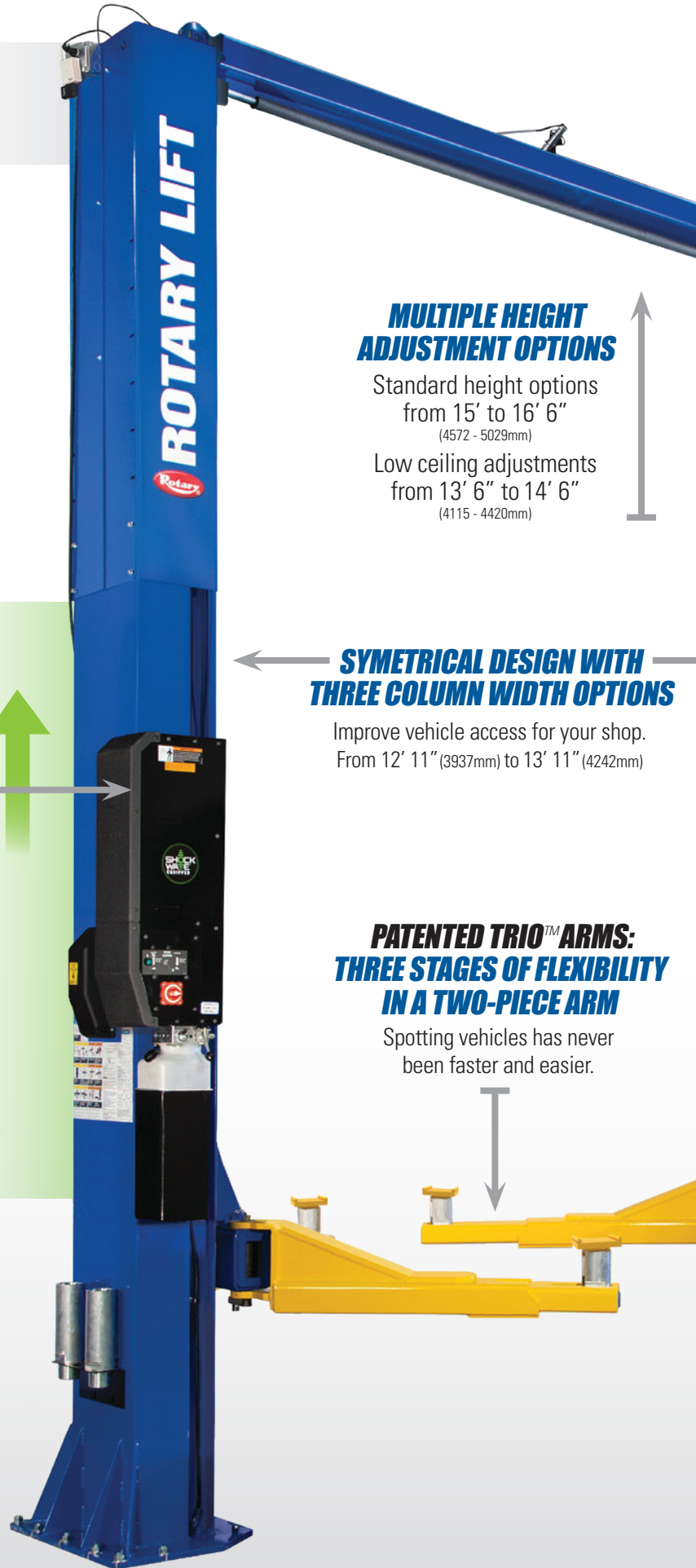

Model shown: SPO20U0T0BL
20,000 lbs. capacity SHOCKWAVE-equipped lift

SINGLE-PIECE OVERHEAD

Robust design for greater strength.



THREAD-UP ADAPTERS FOR EASY VEHICLE CONTACT

Adjustable adapters with rubber pads come standard with ultra-strong 10" (2 each) and 5" (4 each) stackable adapter extensions.



Minimum Adapter Height: 5 31/32" (152mm)



Maximum Adapter Height: 8 1/32" (203mm)



5" Low Step Height: 10 31/32" to 13 1/32" (278-344mm)

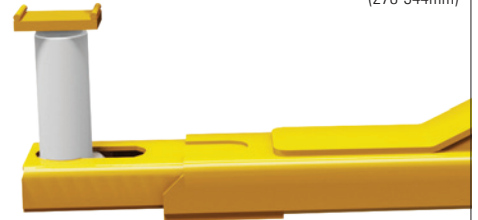

10" High Step Height: 15 31/32" to 18 1/32" (406-470mm)

CLIP ON ADAPTER PADS



Rubber padded adapter clips provide lifting option for spotting unibody passenger cars. Set of four (4) standard.



OPTIONAL ROUND ADAPTERS FOR UNIBODY VEHICLES



Round rubber adapters provide a 3/8" lower profile for pinch weld lifting.

LIFTING CAPACITY:

11,000 lbs. (4989kg) / 2,750 lbs. per arm (1247kg)
#FJ71015KIT for SPO16 / #FJ71016KIT for SPO20

SPO TRIO™ ARMS
22% GREATER ARM REACH

VERSUS CONVENTIONAL 2-STAGE ARMS

GREATER REACH AND RETRACTION

A SPO16 / 20 TRIO ARMS ARM REACH RANGE: 64" to 34-11/16"
ADAPTER AREA COVERAGE: 9,088 SQUARE INCHES

B 2-STAGE ARMS CONVENTIONAL ARM REACH RANGE: 62" to 38-1/2"
ADAPTER AREA COVERAGE: 7,395 SQUARE INCHES

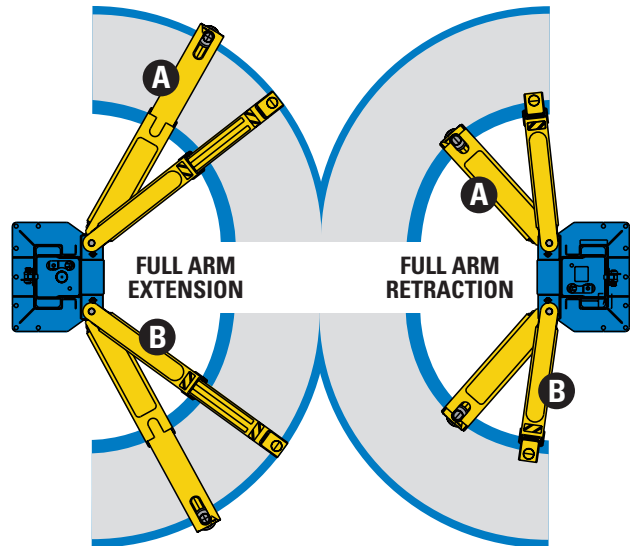



MEASURED IN WIDEST STANCE INSTALLATION



WHEEL SPOTTING DISHES

Two (2) three-position spotting dishes come standard.

LIFT SPECIFICATIONS†

Lifting Capacity	 SPO16 16,000 lbs. (7257kg)
	 SPO20 20,000 lbs. (9072kg)
Max. Load (per arm)	SPO16 4,000 lbs. (1814kg)
	SPO20 5,000 lbs. (2268kg)
Rise°	
A. Min.Truck Adapter Height	77 31/32" (1979mm)
Max.Truck Adapter Height	80 1/32" (2035mm)
Height Overall:	
B. Standard Adjustments	15' to 16' 6" (4572-5029mm)
Low Ceiling (LC)	13' 6" to 14' 6" (4115-4420mm)
Width Overall <small>(outside to outside of base plates)</small>	
C. Narrow	12' 11" (3937mm)
Standard	13' 5" (4089mm)
Wide	13' 11" (4242mm)
Wide setting provides greatest tire clearance for shorter wheelbases	
Drive-Thru Clearance	
D. Narrow	105 11/32" (2677mm)
Standard	111 11/32" (2829mm)
Wide	117 11/32" (2981mm)
E. Floor To Overhead Switch	15' 10 13/16" (4851mm)
F. Reach / Front Arm Min./Max.	34 11/16" (881mm) / 64" (1626mm)
G. Reach / Rear Arm Min./Max.	34 11/16" (881mm) / 64" (1626mm)
H. Min./Max.Truck Adapter Height	5 31/32" to 8 1/32" (152-203mm)
I. Min./Max.Low Step Height	10 31/32" to 13 1/32" (278-344mm)
J. Min./Max.High Step Height	15 31/32" to 18 1/32" (406-470mm)
Inside Columns	
K. Narrow	120 15/32" (3061mm)
Standard	126 15/32" (3213mm)
Wide	132 15/32" (3366mm)
Motor / Voltage**	4 HP / 208v-230v
With SHOCKWAVE	5 HP / 110v
Time of Full Rise	81 seconds at full capacity
With SHOCKWAVE***	60 seconds at full capacity 36 seconds at half capacity
Time of Descent	20 seconds for all vehicles
Ceiling Height Required:	
Standard	15' 2" to 16' 8" (4576-5080mm)
Low Ceiling (LC)	13' 8" to 14' 8" (4166-4470mm)
Min. Bay Size	15' x 30' (4572 x 9144mm)
Total Product Weight	3,500 lbs.

° Rise is measured from floor to adapter in lowest and highest position

** Optional DC SHOCKWAVE battery power available

*** Actual rise times may vary depending on weight of the vehicle

Standard color of lifts are blue and red unless otherwise noted. Gray and black are available at no additional charge. Additional colors are available, consult your Rotary® representative for details.

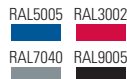

Models: SPO16 / SPO20

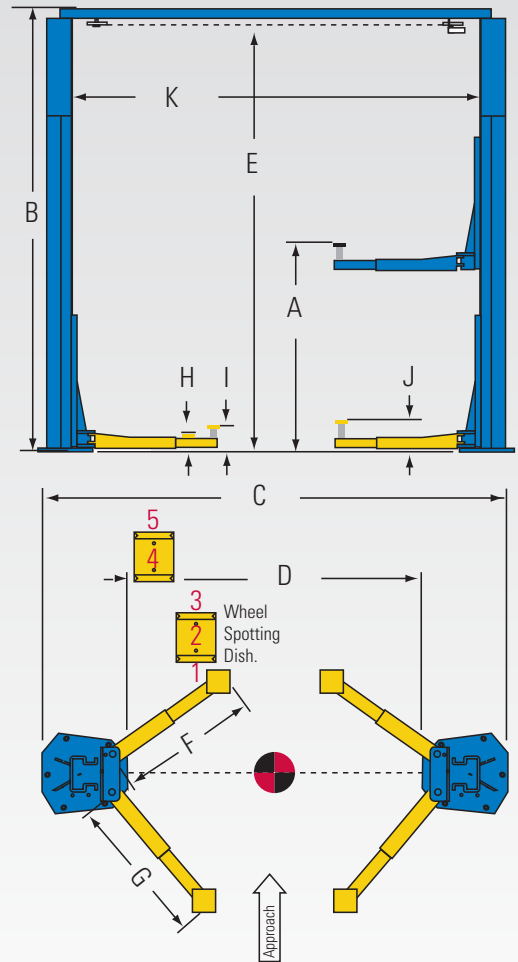

STANDARD / OPTIONAL LIFT FEATURES

FEATURE	Standard Feature ●	SPO16	SPO20
	Optional Feature ○	16,000 lbs.	20,000 lbs.
Lift column design		Symmetric	Symmetric
ALI Certified		●	●
Surface mounted models		●	●
3-stage TRIO™ arms		●	●
Automatic arm restraints		●	●
Single point air lock release		●	●
Multi-position locking systems		●	●
Original single piece "Double S" column construction		●	●
Hydraulic cylinders in each column		●	●
Overhead cables / clear floor design		●	●
Overhead padded switch bar		●	●
Multi-position wheel spotting dish		●	●
Seismic rated column baseplate		○	○
Low ceiling model available		○	○
SHOCKWAVE™ Equipped models		○	○

†NOTE: Level bay floors provide the best underbody clearance needed to accommodate the broadest range of vehicles to spot and lift. Wide setting installations create the best tire clearance on shorter wheelbases.

Vehicle axle weight MUST NOT EXCEED one half of total lift capability.

Maximum arm load is 1/4 of lift rated capacity.

ROTARY LIFT SPO16/20

HEAVY-DUTY SYMMETRIC TWO-POST LIFTS



Service your whole fleet with one lift.

All of Rotary's award winning light duty features can be found on our heavy duty two-post lifts. With capacities up to 20,000 lbs. and options like low ceiling and extended width models, you can rest assured we have a lift for your job.

VISION / QUALITY / SAFETY

ROTARY LIFT PRODUCT BENEFITS

ENGINEERED FOR PRODUCTIVITY

For decades, Rotary® has been the recognized leader in vehicle service lifts. This legendary reputation has set the standard for quality, durability, reliability and attention to safety throughout the automotive service market.

SERVICE AND SUPPORT

With Rotary lifts, you have the service and support you need. Our world-wide network of service companies are always standing by.

THIRD-PARTY GOLD CERTIFIED

Rotary lifts are third party tested by ETL and certified by ALI to meet or exceed strict ANSI standards such as cable cut and deformation tests. Be sure the lift you buy has the gold ALI/ETL label that assures your lift has been tested to meet these standards.



Rotary Lift
2700 Lanier Drive
Madison, IN 47250, USA



North / South America Contact Information

Sales: p 800.640.5438
e userlink@rotarylif.com
Tech. Support: p 800.445.5438
e techlink@rotarylif.com

Global Contact Information

USA: 1.812.273.1622
Canada: 1.905.812.9920
Latin America / Caribbean: 1.812.273.1622
Brazil: +55.11.4534.1995

Assistance for Government Purchasing

Government Sales: 800.445.5438 X5655



Lit# Rotary_SPO16_20_Brochure_2018.08

©2018 VEHICLE SERVICE GROUP™, Printed in U.S.A., All Rights Reserved. Unless otherwise indicated, ROTARY LIFT, VEHICLE SERVICE GROUP™, DOVER and all other trademarks are property of Dover Corporation and its affiliates.

Trio Arms™ (US Patent No. 8,973,712 / US Patent No. 9,550,658)

For additional world wide contact information and a complete guide to our product offering, visit us on the web at rotarylif.com.